

2 Wire Continuous Ultrasonic Transmitters - Standard and Sanitary Mtg.



730 The Kingsway Peterborough, Ont. K9J6W6 Canada
 Tel: (705) 740 - 2010 Web: www.abmsensor.com
 Fax: (705) 740 - 2563 E-mail: info@abmsensor.com

FEATURES

S.S. 316L Face Material c/w Ferrule Mtg. Base
 Simple push-button calibration
 Output 4-20 mA, 20-4 mA
 Built-in temperature compensation
 Compact Size for Easy Mounting

APPLICATIONS

Food and Beverages
 Water/Wastewater
 Chemicals
 Oils

MECHANICAL

Conduit Entry : 1/2" NPT Hole (PVC Conduit only)
 Enclosure : PVC - 94V0
 Sensor : Standard - PVC,
 : Optional - Teflon (standard mtg. only)
 : S.S. (sanitary only)
 Ingress Protection : NEMA 4X (IP65)
 Special Order: NEMA 6 (IP68) N/A for Sanitary Mtg.

ENVIRONMENTAL

Temperature :
 Electronics Enclosure :- 40 to 140°F (-40 to 60°C)
 Continuous Operation
 Std. Sanitary Nozzle :- 40 to 140°F (-40 to 60°C)
 No Steam Cleaning (CIP)
 S.S. Sanitary :- 40 to 266°F (-40 to 130°C) for Steam
 Cleaning only, not for Continuous Operation.
 Pressure Std. : 2 bar
 Optional : 5 bar max. using HTP Sanitary Sensor
 Approvals : Intrinsic Pending
 Installation Category : Class II

OPERATIONAL

Accuracy : +/-0.1% of Max. span
 (in lab using 4-20mA current output)
 +/-0.25% of max. range (typically in field)
 Response Time: Standard Unit 2 - 3 echo's / sec.
 : Std. with less damping 6 echo's / sec.
 IF Required : Fast Protocol 10 - 30 echo's / sec.
 Beam Angle : 10 - 12 degree at -3dB
 Loss of Echo : Hold 30 seconds, 22 or 3.5 mA (avg.)
 Calibration : Push-button
 Temperature Comp. : In transducer
CAT. NO. - On the Web return to Home Page & Refer to Catalogue
 Number Structure for ordering Information. In Product Documenta-
 tion

ELECTRICAL SPECIFICATIONS

Power ABM200	12 to 28 VDC 0.025 A max @ 24 Vdc
Output	4-20 mA Output 6 uA Resolution

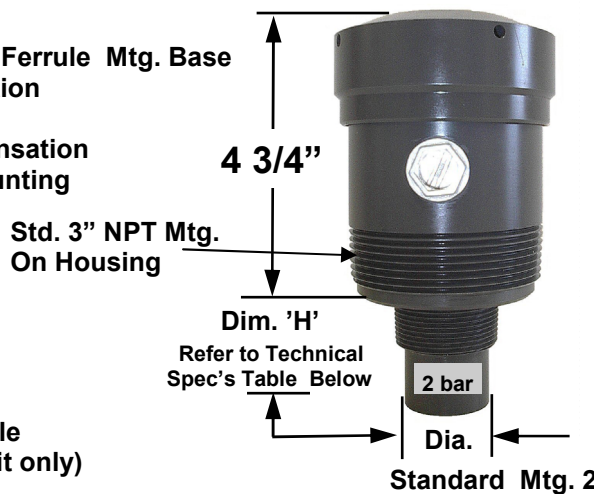

Standard Mtg. 2



Optional HTP
 Sanitary High Temp. / Pressure
 1 1/2" or 2" S.S. Ferrule Mounting

Calibration — 4 -20 or 20 - 4 mA Output

FULL — Calibrate 20 mA or 4mA (Set Near Target)

1. Calibration mode LED color is Blinking Green.
2. Push button and hold until LED turns Yellow (20 mA) or push button and hold until LED turns Red (4 mA)
3. Release button, observe LED flashes to acknowledge the calibration.

EMPTY— Calibrate 4 mA or 20 mA (Set Far Target)

1. Calibration mode LED color is Blinking Green.
2. Push button and hold until LED turns Red (4 mA) or push button and hold until LED turns Yellow (20 mA)
3. Release button, observe LED flashes to acknowledge the calibration.

LOSS OF ECHO—22mA or 3.5 mA

1. To choose 22mA press and hold button until the light goes off—2 flashes
2. To choose 3.5mA press and hold button until the light goes off—1 flash

Range Code	OPERATING RANGE In Liquids	Resolution	Mounting
052	0.9 - 50 ft. 0.27 - 15.2 m	0.23" 5.7mm	2.0" NPT 1.8"Ø x 2.25"H
070	0.8 - 30 ft. 0.24 - 9.1 m	0.13" 3.4 mm	2.0" NPT 1.8"Ø x 2.25"H
080	0.7 - 20 ft. 0.21 - 6.1 m	0.088" 2.2 mm	2.0" NPT 1.8"Ø x 2.25"H
081	0.6 - 16 ft. 0.18 - 4.9 m	0.07" 1.8 mm	1.5" NPT 1.5"Ø x 2.1" H
148	0.4 - 9 ft. 0.12 - 2.7 m	0.04" 0.98 mm	1.0" NPT 1.1"Ø x 2.0" H

2 Wire Ultrasonic Transmitter User Instruction Manual



730 The Kingsway Peterborough, Ont. K9J6W6 Canada
Tel: (705) 740 - 2010 Web: www.abmsensor.com
Fax: (705) 740 - 2563 E-mail: info@abmsensor.com

Fig. # 1 - "2 Wire Sensor" Wiring Connection

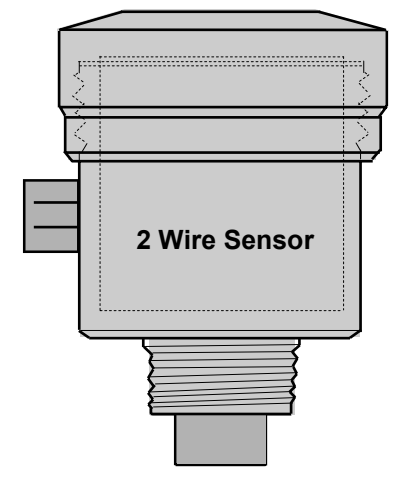
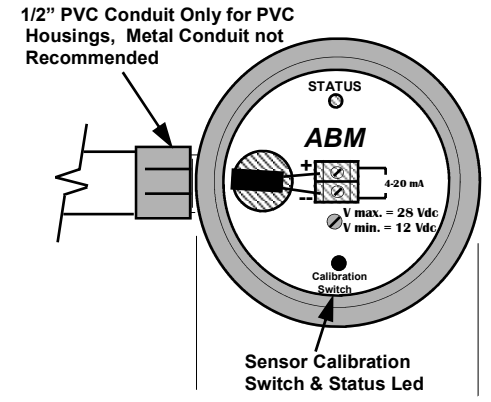
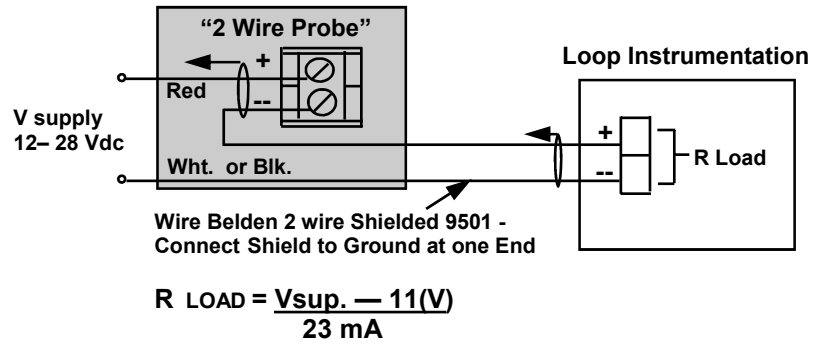

Typical Installation

- 1) DIRECT MOUNTING ULTRASONIC SENSOR -SIMPLY THREAD SENSOR DIRECTLY INTO METAL OR PLASTIC NOZZLE.

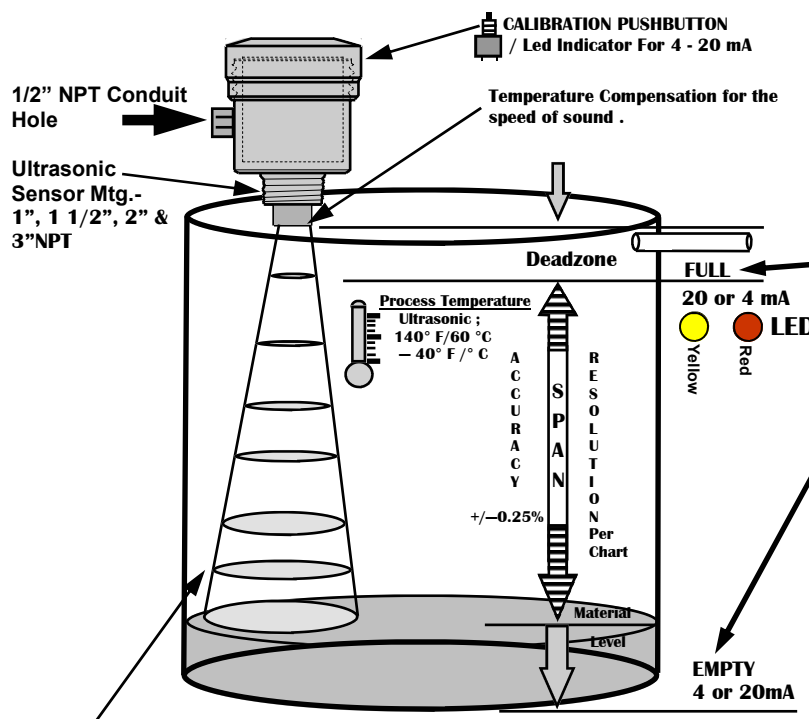

Operation - An ultrasonic pulse is transmitted from the ABM sensor . The pulse travels to the surface being monitored and is reflected off this surface back to the sensor . The time of flight is divided by 2 and converted to an output signal directly proportional to the material level .

Calibration - 4 -20 or 20 - 4 mA Output

- FULL - Calibrate 20 mA or 4mA (Set Near Target)**
1. Calibration mode LED color is Blinking Green.
 2. Push button and hold until LED turns Yellow (20 mA) or push button and hold until LED turns Red (4 mA)
 3. Release button, observe LED flashes to acknowledge the calibration.
- EMPTY- Calibrate 4 mA or 20 mA (Set Far Target)**
1. Calibration mode LED color is Blinking Green.
 2. Push button and hold until LED turns Red (4 mA) or push button and hold until LED turns Yellow (20 mA)
 3. Release button, observe LED flashes to acknowledge the calibration.

- LOSS OF ECHO-22mA or 3.5 mA**
1. To choose 22mA press and hold button until the light goes off-2 flashes
 2. To choose 3.5mA press and hold button until the light goes off-1 flash

2 ,3 & 4 Wire Sanitary Ultrasonic Transmitters Outline Dimensional Dtl.



730 The Kingsway Peterborough , Ont. K9J6W6 Canada
Tel: (705) 740 – 2010 Web: www.abmsensor.com
Fax: (705) 740 – 2563 E-mail: info@abmsensor.com

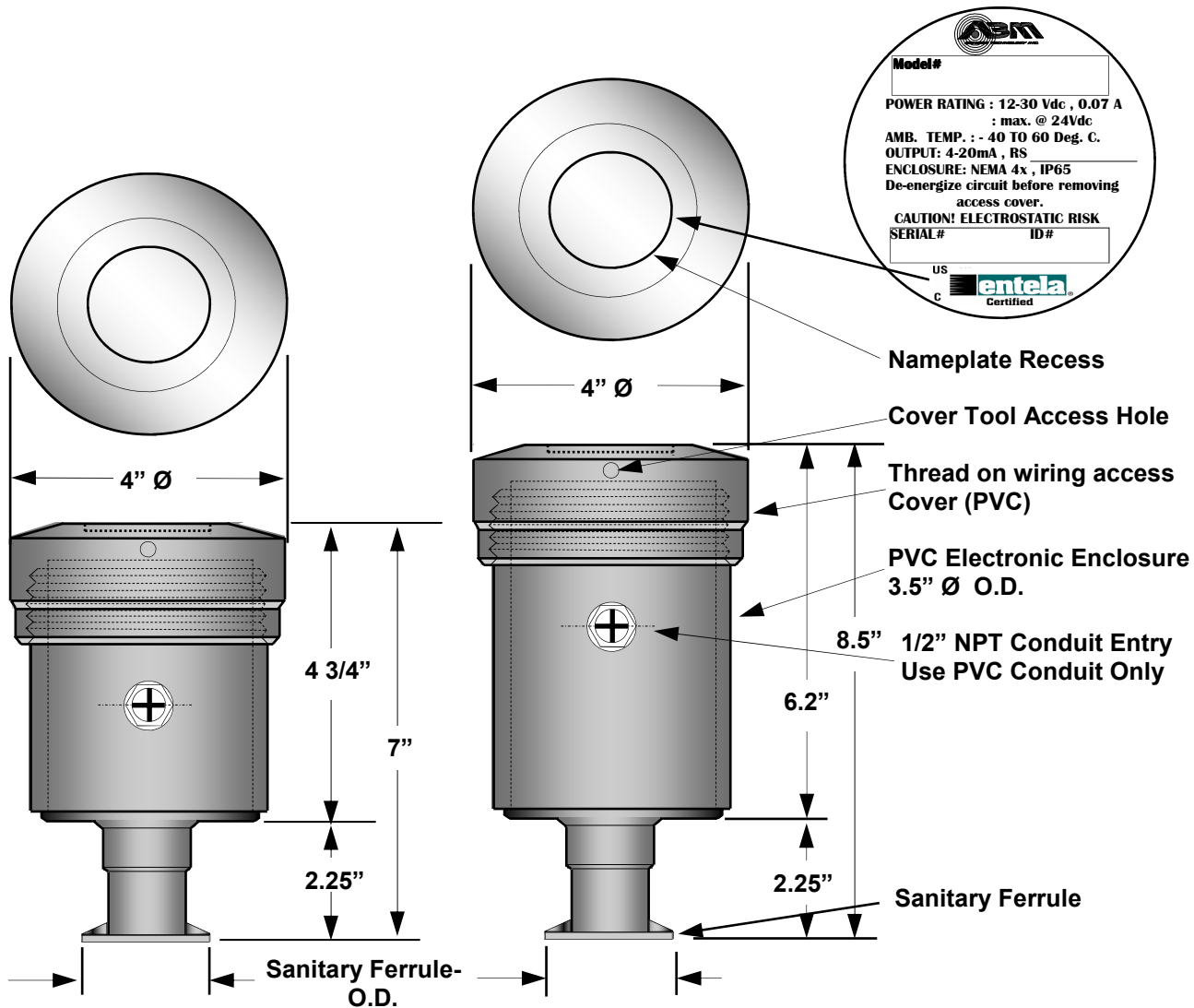

ABM 2 Wire Loop powered Probe

ABM 3&4 Probe

Model #	Operating Liquid Range	Operating Frequency	Level Sensor PVC Housing	
			Sanitary Ferrule O.D. 1.5"	2"
ABMXXX- 070ULCX-PVS20	30'	70 KHz	N/A	2.5"
ABMXXX- 080ULCX-PVS20	20'	80 KHz	N/A	2.5"
ABMXXX- 081ULCX-PVSXX	16'	81 KHz	1.9"	2.5"
ABMXXX- 148ULCX-PVSXX	9'	148 KHz	1.9"	2.5"