

"Smart" Radar Explosion Proof Measurement Sensors



730 The Kingsway Peterborough, Ont. K9J6W6 Canada
 Tel: (705) 740 - 2010 Web: www.abmsensor.com
 Fax: (705) 740 - 2563 E-mail: info@abmsensor.com

FEATURES

Self Adjusting Tracking Radar
 Output 4-20 mA / 20- 4mA
 Recommended RS232 or RS485
 For communications with calibration, diagnostics & data logging software
 PLC compatible (Modbus RTU)
 Three Wire Operation

APPLICATIONS

Water / Wastewater
 Chemicals with vapors

MECHANICAL

Conduit Entry : 1/2" NPT
 Enclosure : Aluminum /S.S.- 94V0
 Ingress Protection : TYPE 4/4X ,
 NEMA 4 (IP65)

ENVIRONMENTAL

Approved : FMc for Can. & US Explosion Proof
 Class I, Div.1, Groups B, C, D:
 Dust-Ignition Proof Enclosure for
 Class II/III Div. 1, Groups E, F, G
 Approvals : FCC Part 15 - Low
 Power Communication Device
 Temperature : - 40 to 140°F (- 40 to 60°C)
 Installation Category : Class II

Catalogue # - On the Web return to Home Page & refer to Catalogue Number Structure for ordering information. In Product Documentation refer to page 5.

TECHNICAL SPECIFICATIONS

Radar Range Code	RANGE In Liquids	RESOLUTION	MOUNTING
033	* - 33 ft. * - 10 m	0.15" 3.9 mm	2.0", 1 1/2" NPT **
050	* - 50 ft. * - 15 m	0.22" 5.7 mm	2.0", 1 1/2" NPT **
100	* - 100 ft. * - 30 m	0.44" 11 mm	2.0", 1 1/2" NPT **
240	* - 240 ft. * - 73 m	1.06" 26 mm	2.0", 1 1/2" NPT **

Note - * Minimum Distance starts at the lower tip of the antenna .
 -** Only 2" NPT Mtg. Connection Available on High Temp. Unit

OPTIONAL

Antenna Extension : 6" or 8" Lengths
 - Use only with Teflon Antenna !
 - Refer to catalogue number Page for ordering info.
 High Temperature Unit :
 - 2" / 1 1/2" NPT Process Connection
 - Teflon De-coupler threads on with 2" NPT Process Connection.

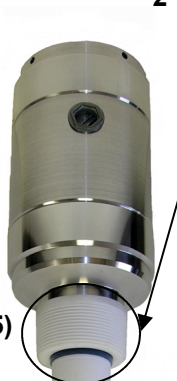

Antenna Extension

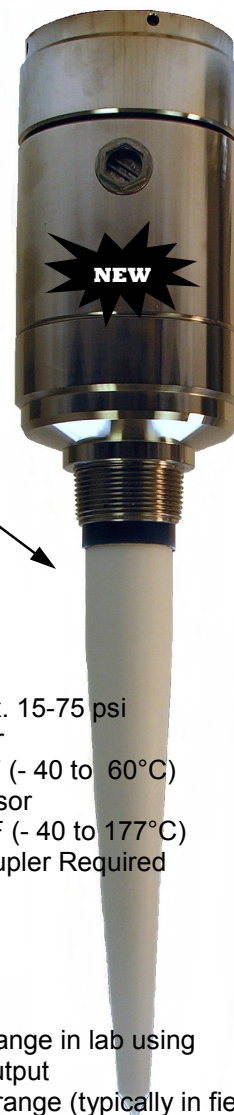

PROCESS

Material Dielectric : Er >2
 Pressure : 5 bar Max. 15-75 psi
 Temperature : - Std. Sensor
 PP Rod : - 40 to 140°F (- 40 to 60°C)
 High Temp. Optional Sensor
 PTFE Rod : - 40 to 350°F (- 40 to 177°C)
 Teflon Temperature Decoupler Required

OPERATIONAL

Operation : Pulse Radar
 Accuracy : +/- 0.1% of max. range in lab using
 4-20mA current output
 +/-0.25% of max. range (typically in field)
 Frequency : 6.3 GHz
 Loss of Echo Hold : 1 min., 22mA or 2mA output
 Transmitter Power : 50 uW average
 Calibration : via optional communications port.
 (required)
 Diagnostics: (Echo Profile) via communications port
 Antenna : Dielectric rod PP or Optional PTFE

ELECTRICAL SPECIFICATIONS

Power DC 12 to 30 VDC , 0.07 A max @ 24 Vdc
 ABM300 R load = (Vs — 6) / 24 mA

Output 4-20 mA Output 6.1 uA resolution
 Optional RS232 or RS485
 communications port

3 & 4 Wire Ultrasonic and Radar Sensors User Instruction Manual



730 The Kingsway Peterborough, Ont. K9J6W6 Canada
 Tel: (705) 740 – 2010 Web: www.abmsensor.com
 Fax: (705) 740 – 2563 E-mail: info@abmsensor.com

Inter-Connection Diagram Top View of Sensor (Access Cover Removed)

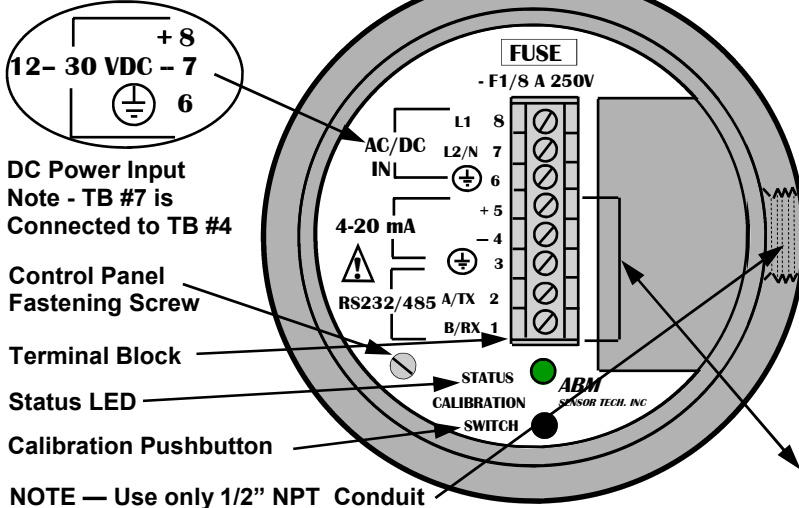

Typical Installation

- 1) Direct mounting ultrasonic sensor - Simply thread sensor directly into metal or plastic nozzle.
- 2) Radar unit must be installed into metal fitting with the antenna pointing downward.
- 3) Do not mount in the center of a domed tank.

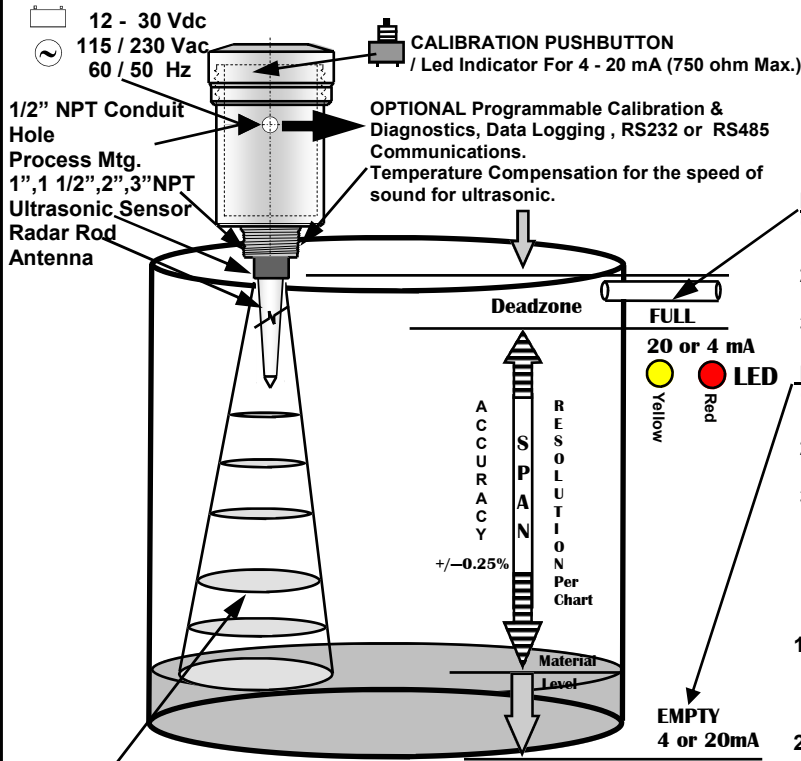

Operation - An ultrasonic/electromagnetic pulse is transmitted from the ABM sensor . The pulse travels to the surface being monitored and is reflected off this surface back to the sensor . The time of flight is divided by 2 , corrected with temp. and converted to an output signal directly proportional to the material level .

FCC INFORMATION TO RADAR USERS

NOTE: This equipment has been tested and found to comply with the limits for a Class A digital device, pursuant to Part 15 of the FCC Rules. These limits are designed to provide reasonable protection against harmful interference when the equipment is operated in a commercial environment. This equipment generates, uses, and can radiate radio frequency energy and, if not installed and used in accordance with the instruction manual, may cause harmful interference to radio communications. Operation of this equipment in a residential area is likely to cause harmful interference in which case the user will be required to correct the interference at his own expense.

WARNING-Changes or Modifications not expressly approved by ABM Sensor Technology Inc. could void the user's authority to operate the equipment.

Wiring Information

- Ground shield at one end only.
- All terminal block wiring must be rated for 250V.
- Power input wiring must be protected by a 15A double pole circuit breaker .
- Terminal is for use only with equipment which has no live parts which are accessible .
- Terminal is for use with equipment which maintains basic insulation from hazardous voltage under normal and single fault conditions .

Connection used at the remote end of external circuit .

Recommended Wiring

For AC Sensor —

Power 3 Wire unshielded 22 AWG , 300 V
 Current Output 1 Pair shielded 24 AWG , 300 V
 Communication 1 Pair shielded 24 AWG , 300 V

For DC Sensor—

Power & Current output 3 Wire shielded 24 AWG , 300 V
 Communication 1 Pair shielded 24 AWG , 300 V

Calibration — 4 -20 or 20 - 4 mA Output

For Radar programmable through communication is recommended.

FULL — Calibrate 20 mA or 4mA (Set Near Target)

1. Calibration mode LED color is Green.
(for Radar Low Dielectric Materials has to be off)
2. Push button and hold until LED turns Yellow (20 mA) or push button and hold until LED turns Red (4 mA)
3. Release button, observe LED flashes to acknowledge the calibration.

EMPTY— Calibrate 4 mA or 20 mA (Set Far Target)

1. Calibration mode LED color is Green
(for Radar Low Dielectric Materials has to be off)
2. Push button and hold until LED turns Red (4 mA) or push button and hold until LED turns Yellow (20 mA)
3. Release button, observe LED flashes to acknowledge the calibration.

For Radar to turn the Low Dielectric Materials operation mode ON and OFF (this mode is recommended for materials with dielectric constant lower than 4 and also to eliminate multiple reflections in tank.)

- 1) To turn the Low Dielectric Materials ON. Push button and hold until LED goes OFF after the sequence of Yellow , Red and turns Off. The Low Dielectric Material operation is On when the LED'S Green light blinks constantly.
- 2) To turn the Low Dielectric Materials OFF. Push button and hold until LED goes OFF after the sequence of Yellow , Red and Turns OFF. The Low Dielectric Material operation is OFF when LED is continuously Green.
- 3) Use communication software.

3&4 Wire Ultrasonic and Radar Sensors Communication Interconnection Dtl.



730 The Kingsway Peterborough, Ont. K9J6W6 Canada
 Tel: (705) 740 – 2010 Web: www.abmsensor.com
 Fax: (705) 740 – 2563 E-mail: info@abmsensor.com

Fig. # 1 RS232 Connection

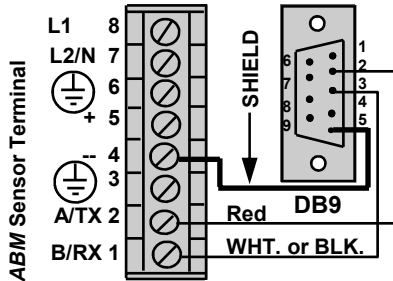

Note – Connect the shield to ABM Sensor Terminal #4.

Fig. # 2 RS485 Connection

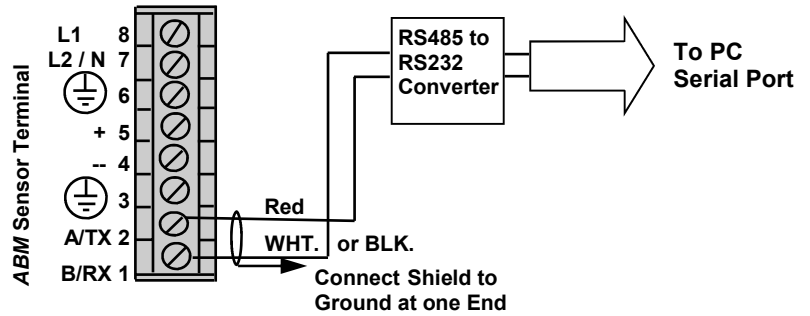

Note – Connect the shield to ABM Sensor Terminal #3.

Connect to Serial Port of PC, use Extension Cable length as required, Refer to Fig.# 1 or # 2 For Wiring Dtl.

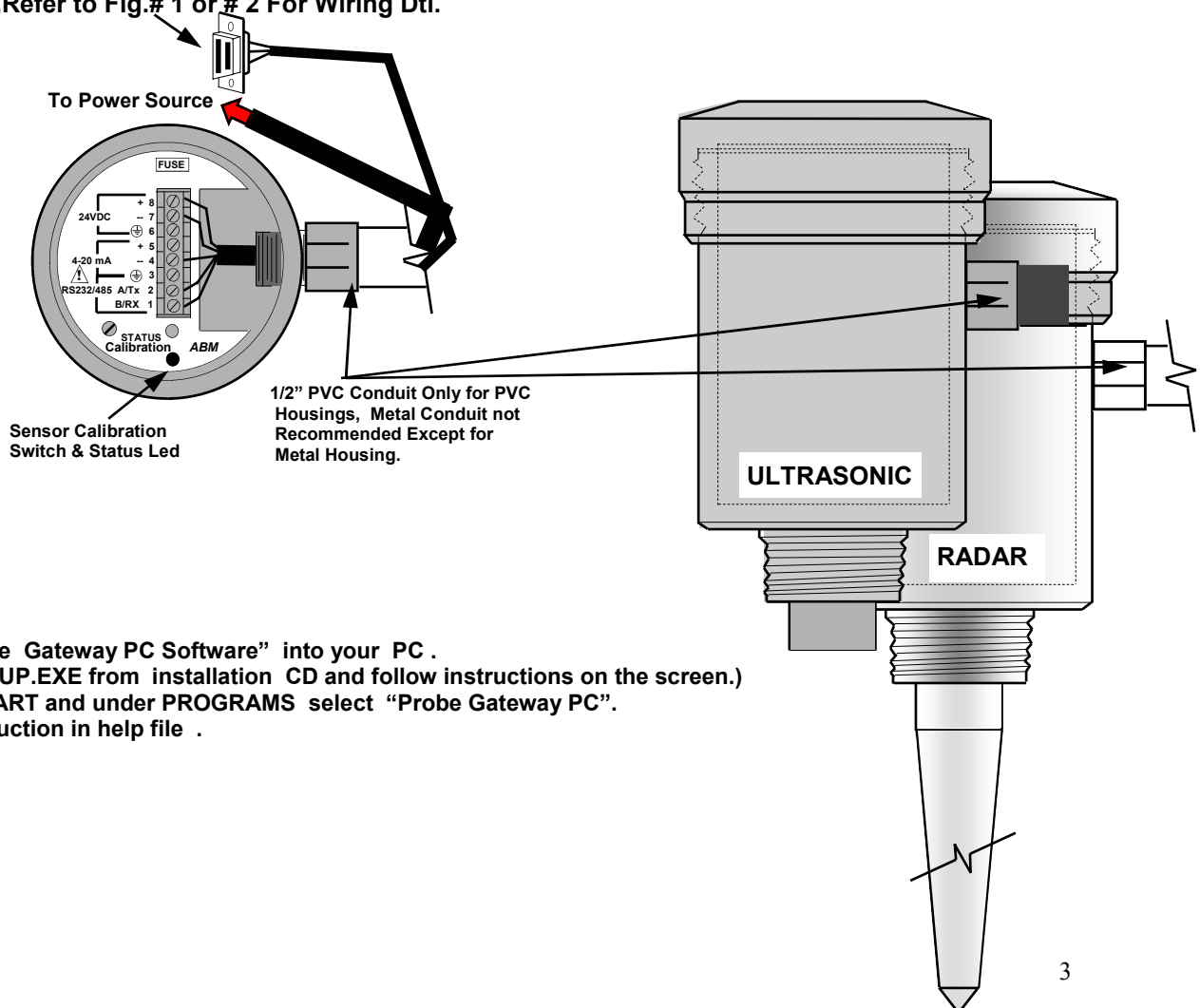

- 1) Load "Probe Gateway PC Software" into your PC .
(Select SETUP.EXE from installation CD and follow instructions on the screen.)
- 2) Click on START and under PROGRAMS select "Probe Gateway PC".
- 3) Follow instruction in help file .

3 Wire Explosion Proof Radar Measurement Sensors Outline Dimensional Dtl.



730 The Kingsway Peterborough, Ont. K9J6W6 Canada
 Tel: (705) 740 - 2010 Web: www.abmsensor.com
 Fax: (705) 740 - 2563 E-mail: info@abmsensor.com

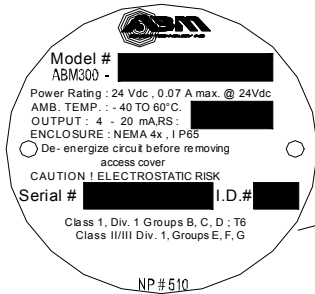

Nameplate Recess

Cover Tool Access Hole

Thread on Wiring access

Cover (Aluminum or S.S.)

1/2" npt Conduit Entry

FCC Nameplate

Mounting Thread
 2" / 1 1/2" NPT

Antenna Teflon

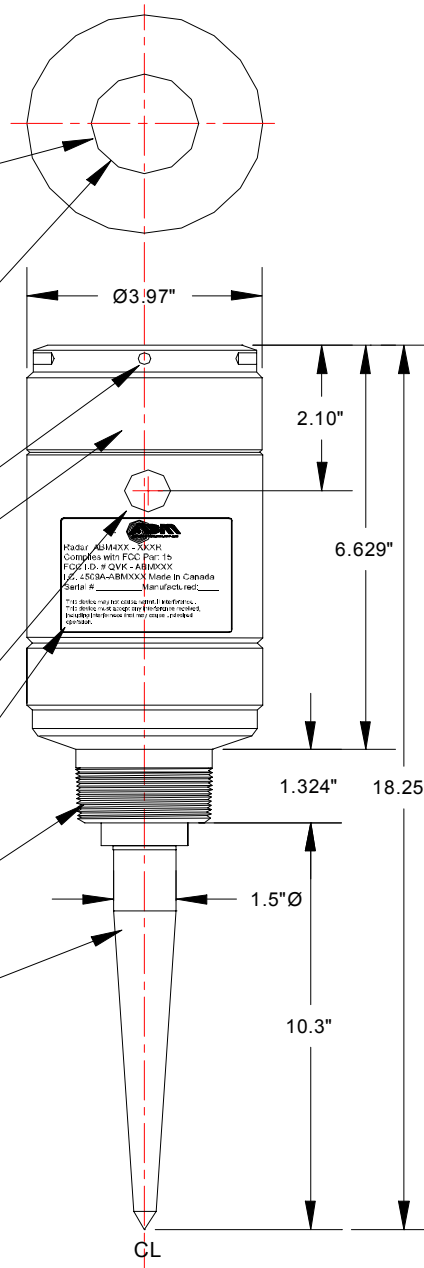

3 Wire Radar Explosion Proof
 Outline Dimensions